



gamepro
all Games For You!

**2022
PRESENTATION:
>>>**

SUMMARY

Introduction	3
Gamer Sector Assembly	4
Custom-made Stands	10
Esports Productions	15
Casters we have worked with	28
On Site Tournaments	30
Gamer Consulting: Product development	36
Multimedia Production	39

XGamePro Studio	41
- Our Service	45
- Featured Works	46
- Our Team	51
- Technical info	56
- The Studio	57
- Scenography & Wardrobe	75
Summary of our Multimedia Productions	82
Brands that have worked with us	83
xgamepro.net 10 years Video	84
Contact Us / Address	85



XGamepro was born in 2011 as an esports competition developer website. As the local scene evolved, XGamePro mutated based on local gaming needs. Finding our existence through gaming is what identifies and differentiates us.

Our strength is to know how to reach the end-user, in actions intended to promote a product online or/and on site, or through the execution of personalized tournaments, as well as any other action our client needs.

We stand out for the professionalism, seriousness and enthusiasm with which we face, on a daily basis, the whole videogames industry, pushing us to work for our passion, and for those reasons we are XGamePro.

- 🏠 Event production
- 🏠 Gamers sector assembly of any kind and size
- 🔧 Customized stands assembly
- 🏠 Corporate stand assembly to IT brand
- 🎮 Online or on site competitions organization
- 🎧 Esport and video games consulting
- 📣 Actions focused to the promotion of a brand, product or service
- 🎮 Product development in the gamer scene
- 🎥 Youtubers and Streamers
- 📺 Multimedial production
- 💻 Software development



GAMER SECTOR ASSEMBLY



VACACIONES DE INVIERNO

LA USINA DEL ARTE





CONECTADOS BA 2019
GOBIERNO DE LA CIUDAD DE BUENOS AIRES

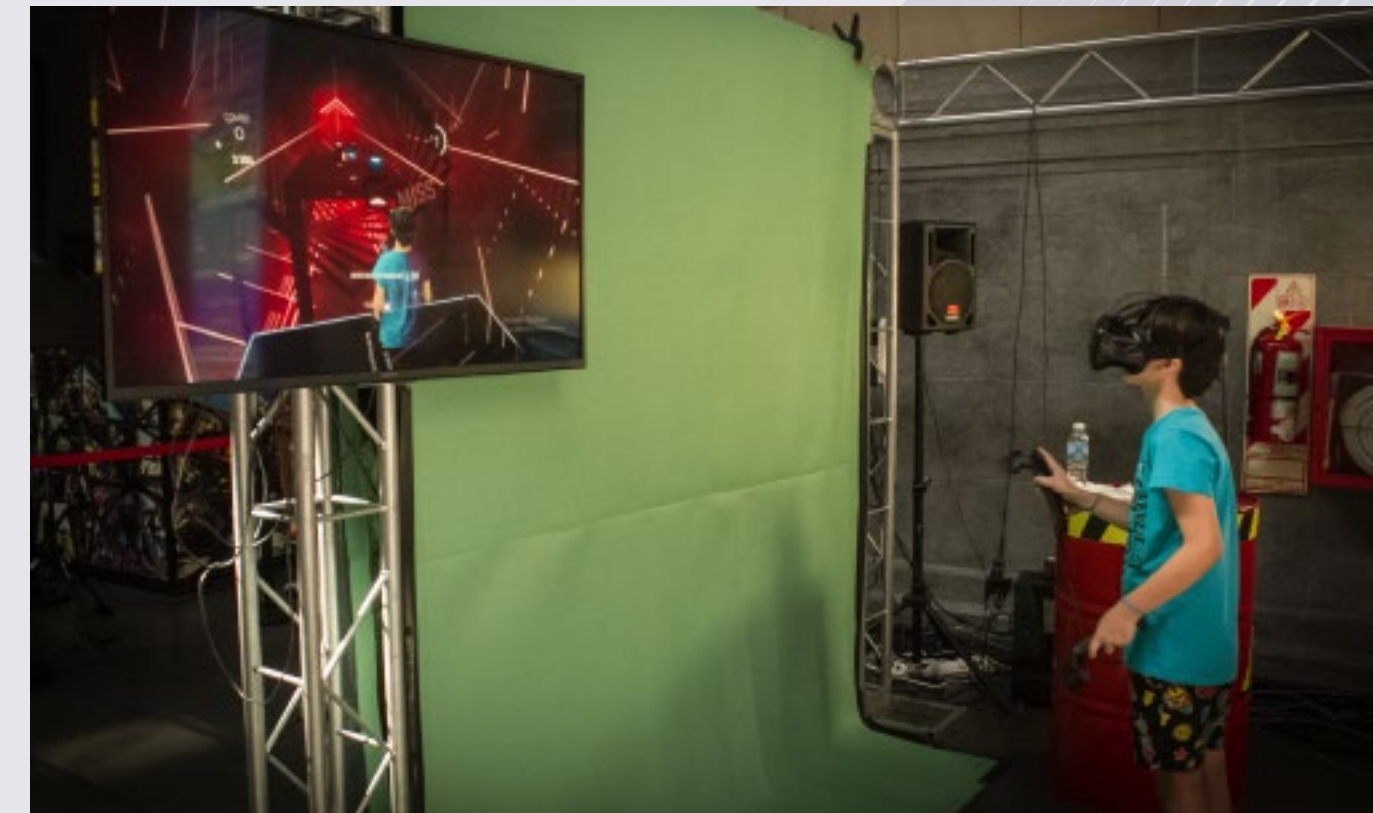



CIUDAD EMERGENTE 2019

GOBIERNO DE LA CIUDAD DE BUENOS AIRES





FINDE

ESTADIO UNICO DE LA PLATA PARA
GOBIERNO DE BUENOS AIRES







CUSTOM-MADE STANDS



GARENA FREE FIRE 2018 STAND

ARGENTINA GAME SHOW





GARENA FREE FIRE 2019 STAND

ARGENTINA GAME SHOW





GARENA FREE FIRE 2019 ESPORTS ARENA

ARGENTINA GAME SHOW





ESPORTS PRODUCTIONS MADE IN OUR STUDIO

NIMO HUAWEI 2020

(FREE FIRE) PARA PLATAFORMA NIMO



GARENA FREE FIRE (OFICIAL)



THE BLAST 2020 (COUNTER STRIKE GO) FOR FIRESPORTS



FIRE LEAGUE 2020 (COUNTER STRIKE GO) FOR FIRESPORTS



ACER 2020 Y 2021 (COUNTER STRIKE GO) FOR ACER & INTEL





REDDRAGON LATAM SERIES 2021 (COUNTER STRIKE GO) FOR REDDRAGON







LADDER CUP 2021 (LEAGUE OF LEGENDS) FOR 1BLOCK



**AXIE
INFINITY 2022**
OFICIAL



LADDER CUP 2022 (LEAGUE OF LEGENDS) FOR 1BLOCK



TLFSPORTS 2022 (VALORANT) FOR TELEFE



CASTERS WE'VE WORKED WITH



ZOMBYRA
📷 6.7K 🐦 5.1K



EFE
📷 13.8K 🐦 9.6K



KEVIN MPV
📷 8.3K 🐦 5.7K



KRONOPIA
📷 13.8K 🐦 4.5K



CRAFERTV
📷 8.8K 🐦 871

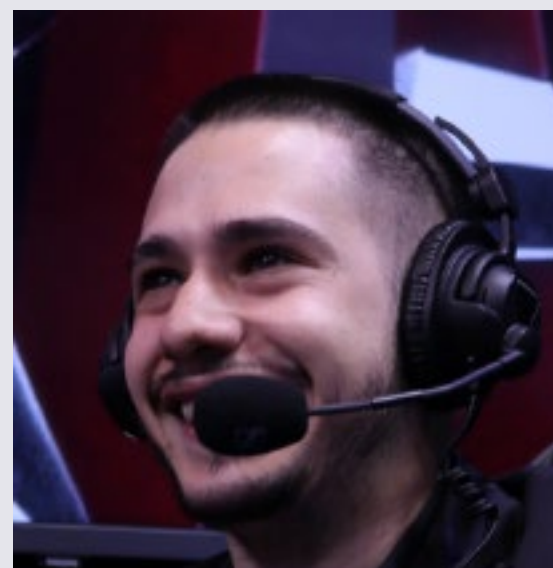

H1RO
📷 4.2K 🐦 4.7K

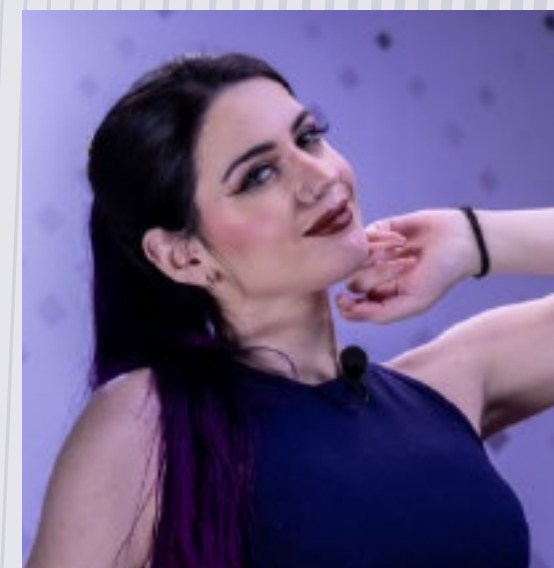

MAGUI.SUNSHINE
📷 217K 🐦 48K



NOSFEH
📷 2.1K 🐦 48.6K



GOTSZAR
📷 1.2K 🐦 1.6K



CAN
📷 1.6K 🐦 42.2K



LUCIUS.HELLSING
📷 8.3K 🐦 10K



BARNALDI
📷 3.7K 🐦 1.1K

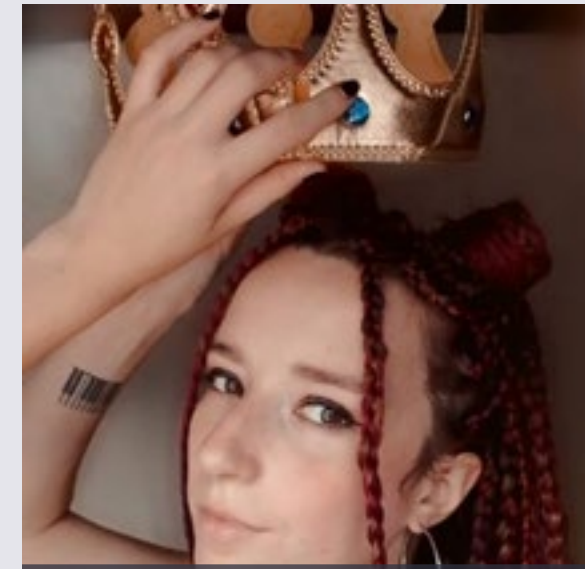

ABOGADITHAIS
📷 2.3K 🐦 835K



ROM
📷 612



CLOVER
📷 1.4K 🐦 5.2K



LAD YHARU
📷 657 🐦 389



OXACIANO
📷 1.1K 🐦 14.6K



ON SITE TOURNAMENTS

LOGITECH G CHALLENGE 2014



MUNDO G 2016 TOURNAMENT



ETERNAL LEAGUE 2018

BLIZZARD



ETERNAL LEAGUE 2019

BLIZZARD



OFICIAL FREEFIRE ESPORTS ARENA

ARGENTINA GAME SHOW 2019





**BAIRES
FREE FIRE 2019 FINALS**

ARGENTINA
GAME SHOW 2019
(MAIN STAGE)



GAMER CONSULTING PRODUCT DEVELOPMENT

As a company specialized in Sports we offer integral consulting to our customer, we can highlight:

- New business units: includes search Enterprise solutions and execution plans tending to intruduce our client to a new market or reach a new target defined.
- Business development: involve the realization of activities destined to Brand or pruduct promotion and difusión
- Generation of meeting point: sustained by the development and creation of activities of Leagues and profesional tournament, executed online or on site, organization evento, arming stand with advertising purpose or as an epicenter of interaction with current or potential consumers
- Enlargement and strengthening of the community: includes the transmission of competetions, management and creation of content on social networks

MOVISTAR: GAMES4YOU

Games4You is the Movistar gamer news portal. In order to promote it, we carry out, under its sponsorship, Clash Royale and FreeFire tournaments on youtubers channels recognized in the gamer environment (Drekzen, Donato, Jeanki).

In this way, a direct promotion of the portal to the public gamer was achieved.

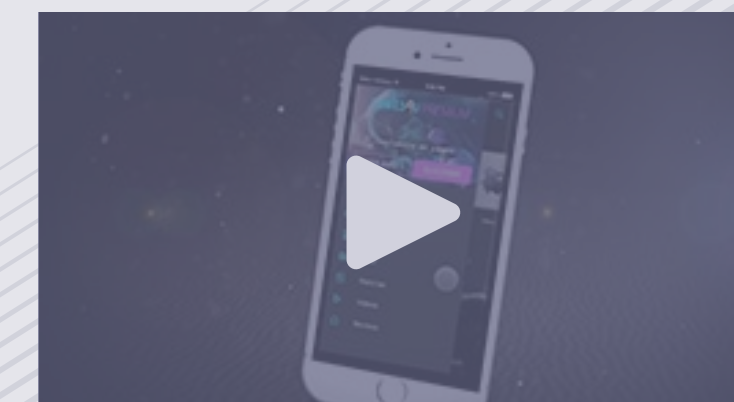
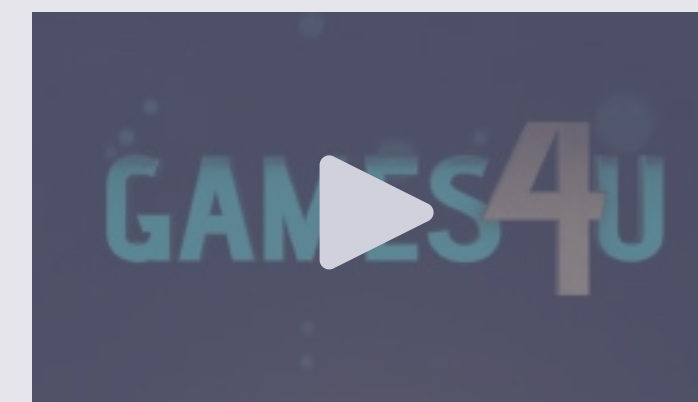

2018: JUEGOS OLÍMPICOS DE LA JUVENTUD

Being the electronic sport the novelty within the international event has taken place in our country, we were under the task of spreading it in advance. Thus, at the Campus party 2016 technology event we managed a stand dedicated to informing about it with sports professionals: Snail (Hearthstone), Patan (FIFA), Nocturns Gaming (Overwatch), Johnnyboy and Straka (CS: GO) , and Nosfeh (Rapporteur driver in stand)

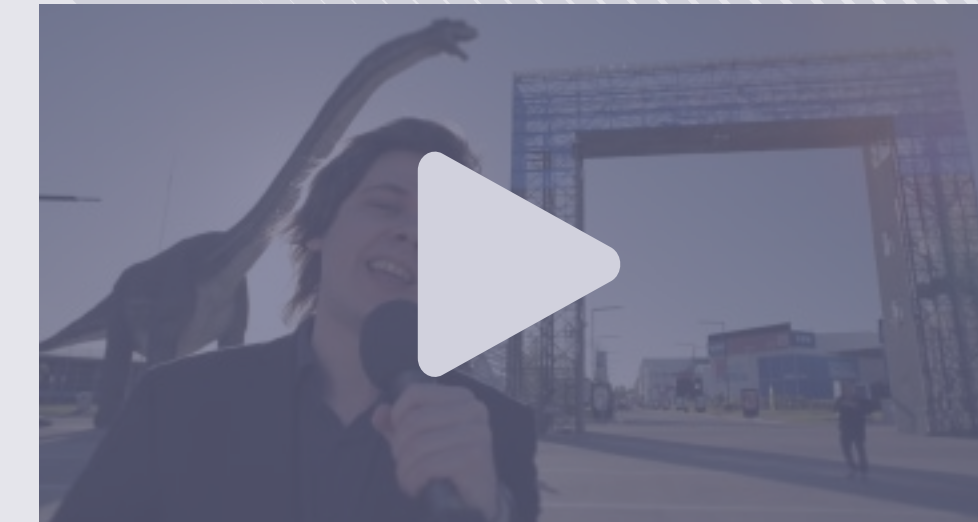

GARENA: FREEFIRE

During 2019 and 2020, in order to promote new in-game procured skins, we conducted multiple photo sessions to professional cosplayers to portray these same skins. The photos were uploaded to social networks capturing not only the attention of players but also those of cosplay lovers.



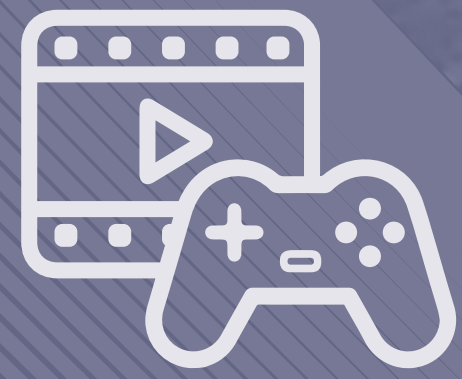

MULTIMEDIA GAMER PRODUCTION

BAIRES FREE FIRE: Online and on site phases

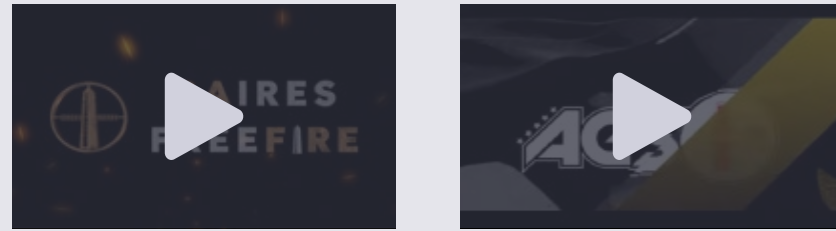

Argentina Game Show 2019: XGamePro in event and Eternal League's stage (Hearthstone tournament)

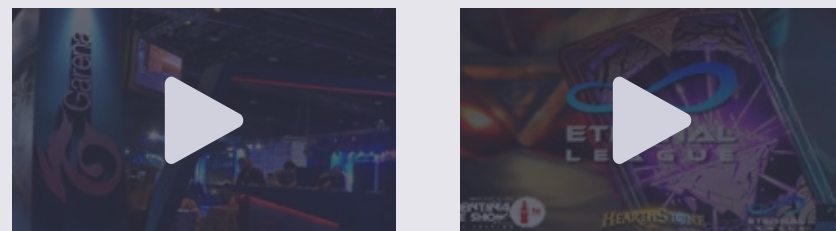

Redragon:

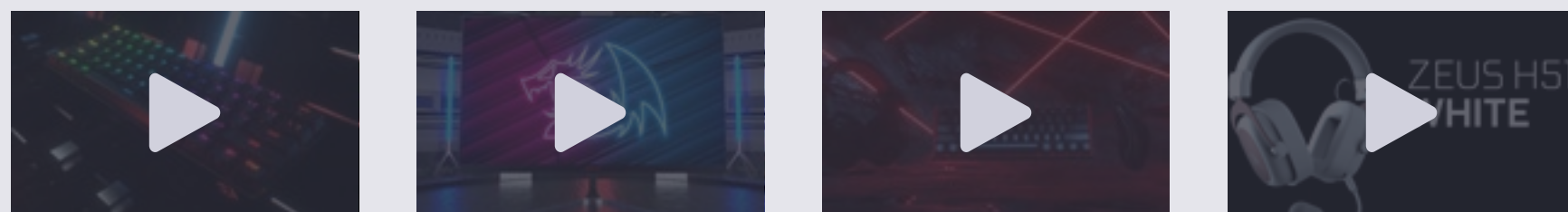

Introduction :



Casa de papel - **NETFLIX & GARENA FREE FIRE**



Redragon latam series
CSGO - **REDRAGON**

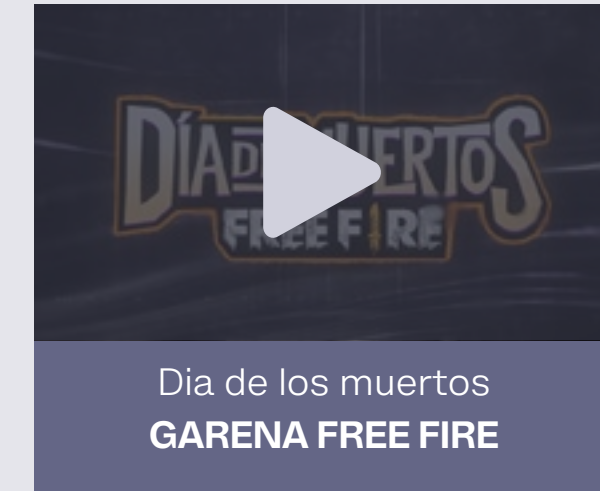

Dia de los muertos
GARENA FREE FIRE

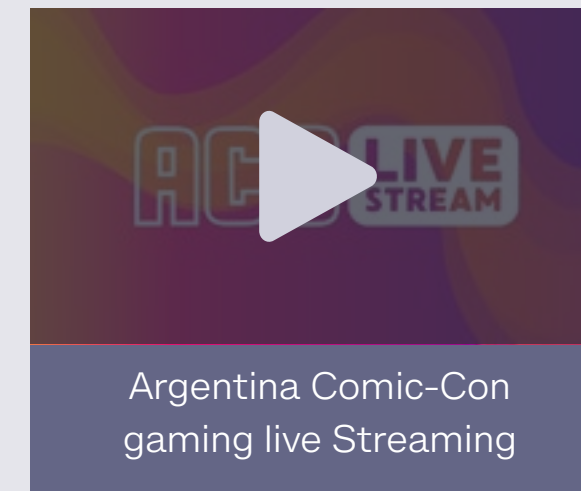

Argentina Comic-Con
gaming live Streaming



TLF Series Cup Valorant
PARAMOUNT TELEFE

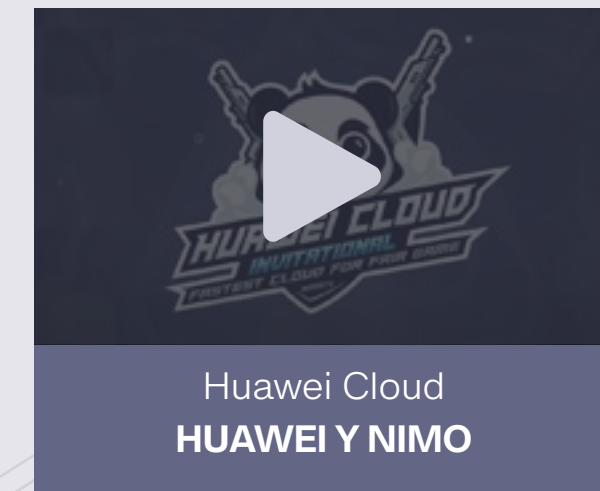

Huawei Cloud
HUAWEI Y NIMO



Ladder Cup league of legends
paraguay - **1BLOCK**



Showmatchs Halloween
GARENA FREE FIRE

XGAMEPRO STUDIO

>>>







XGamePro is a company 100% dedicated to video games and with vast experience in esports. Throughout the ten years we've been around this industry we've carried out a wide repertoire of activities: from producing events, developing gamer sections and building corporative stands to organising offline tournaments and creating digital content, among other tasks.

This 2022 we're taking advantage of the structure we've built around our **professional studio** to diversify our offered services. In addition to our ongoing activities, we're adding the development of custom, **first-grade digital content** for those clients who'd require it. This content includes live broadcasts and pre-recorded media, both for gaming-related companies and for outsiders to this industry.

OUR SERVICE

Through our studio's services, we offer an all-around multimedia production which suits the necessity of any client, getting ourselves deeply involved with the product in order to successfully **meet the expectations of those who've put their trust in us.**

- . Creative advice and counseling
- . Streaming through any and all platforms required, with design, introduction, voice over and filming on up to three simultaneous sets if required
- . Digital content fit to the client's necessities.
- . Tournaments, esports competitions.
- . A completely unique design line, built around the corresponding videogame.
- . Introduction videos with a professional voice over.
- . Pre-recorded content.
- . Custom scenography made for the client's necessities.
- . Announcers and commentators (casters) specialized in esports.
- . Professional sport analysis over the broadcasted competition.
- . Designs apt for chroma backgrounds, both for pre-recorded content and live use.





Magui and Kronopia analyzing last match - Garena FreeFire: Halloween



Additional scene in the backyard - Garena FreeFire: Halloween



Magui and Kronopia - Garena Free Fire: Dia De Muertos



Darkoz, Magui, Krafer, Kronopia and Efe - Garena Free Fire: Dia De Muertos



Efe and KevinMVP presenting the league - FireLeague CS:GO



H1ro analyzing matchs post event - FireLeague CS:GO



Crafer and Efe casting from set#2 - Garena Free Fire: Casa de Papel



Bank projection over the Croma - Garena Free Fire: Casa de Papel



Goncho and Straka presenting Zowie products - Zowie



TecnoBit reviewing gaming peripherals - Redragon

OUR TEAM

XGamePro features a talented group of individuals equipped with the technical tools required to provide the desired result on each and every project we work on.

TECHNICAL STAFF

We offer a multimedia production built around the necessities of our clients, constantly backing up our process with professional and commercial advising. On the technical side of things, our full-time team is comprised of:

- . Live graphic designer
- . Announcer
- . Audio engineer
- . Professional lighting
- . Producer
- . Camera director
- . Art and Photography personnel
- . Cameramen
- . Video editor









TECHNICAL INFO

Full HD and 4K formats



- . Sony HXR-NX80 4K, Camera
- . Sony Handycam 4K Ax40 with “Exmor R” Sensor, Camera
- . CANON EOS 80D, Reflex Camera



- . Mixing consoles with 8 and 12 channels
- . Sennheiser EW 100 G4, wireless microphone
- . Sennheiser HMD 27 2020, headset with microphone



- . Blackmagic X4 HDMI, PCI-e capture cards
- . MAGEWELL (SDI and HDMI) and EVGA (HDMI), external capture cards
- . High-end, gaming-oriented computers



THE STUDIO

Next we'll be showing the plans of our whole building,
together with some examples on how the set can be built

FLOOR PLAN

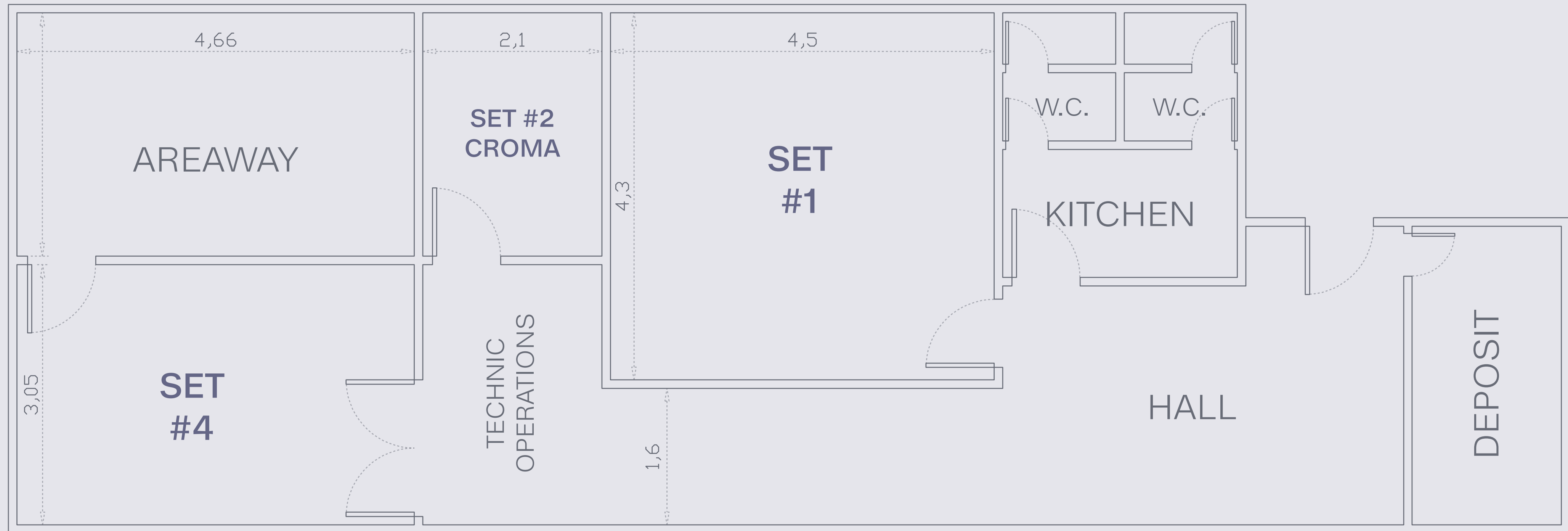

SET #1

EXAMPLE A

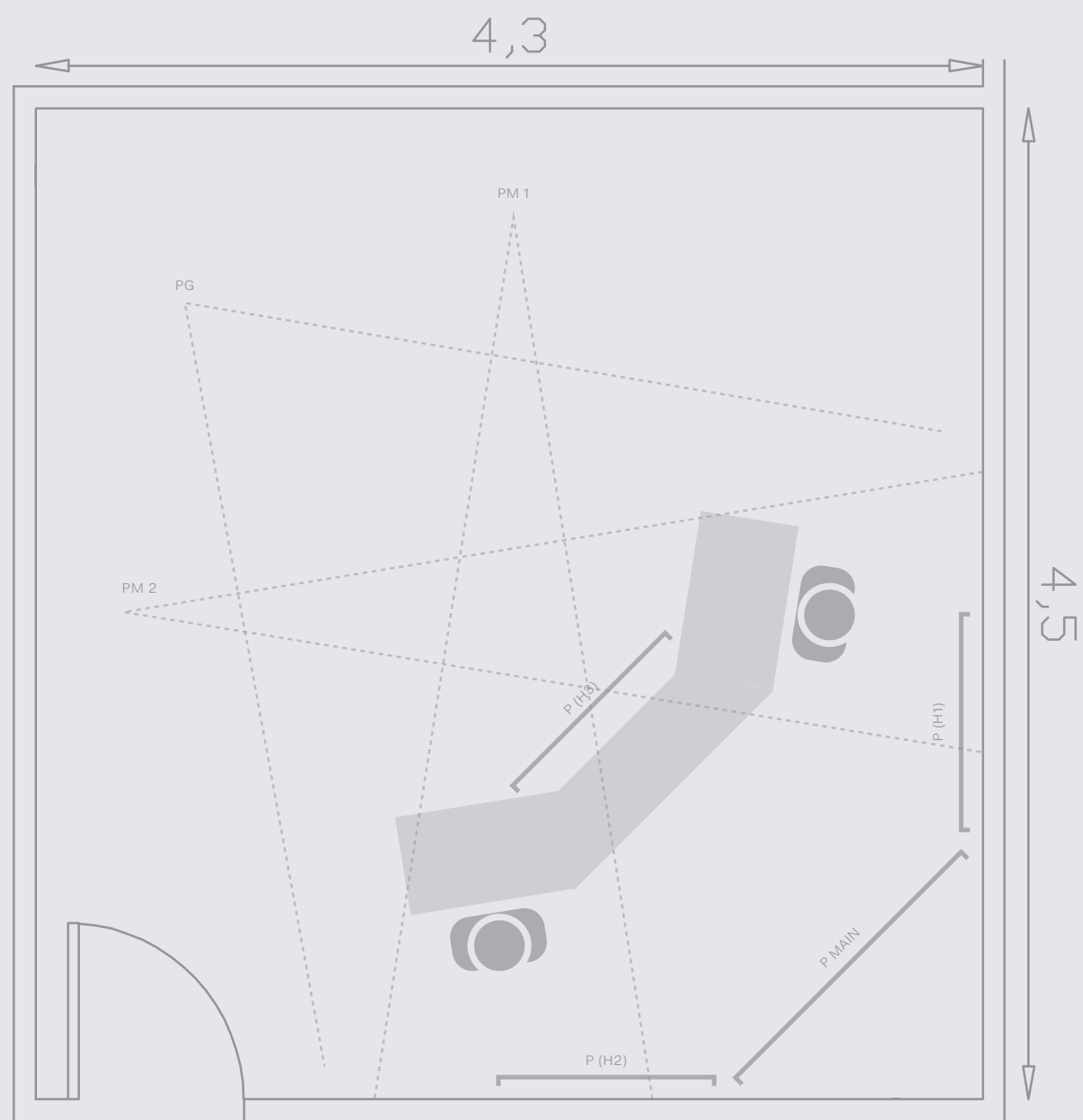



SET #1

EXAMPLE B

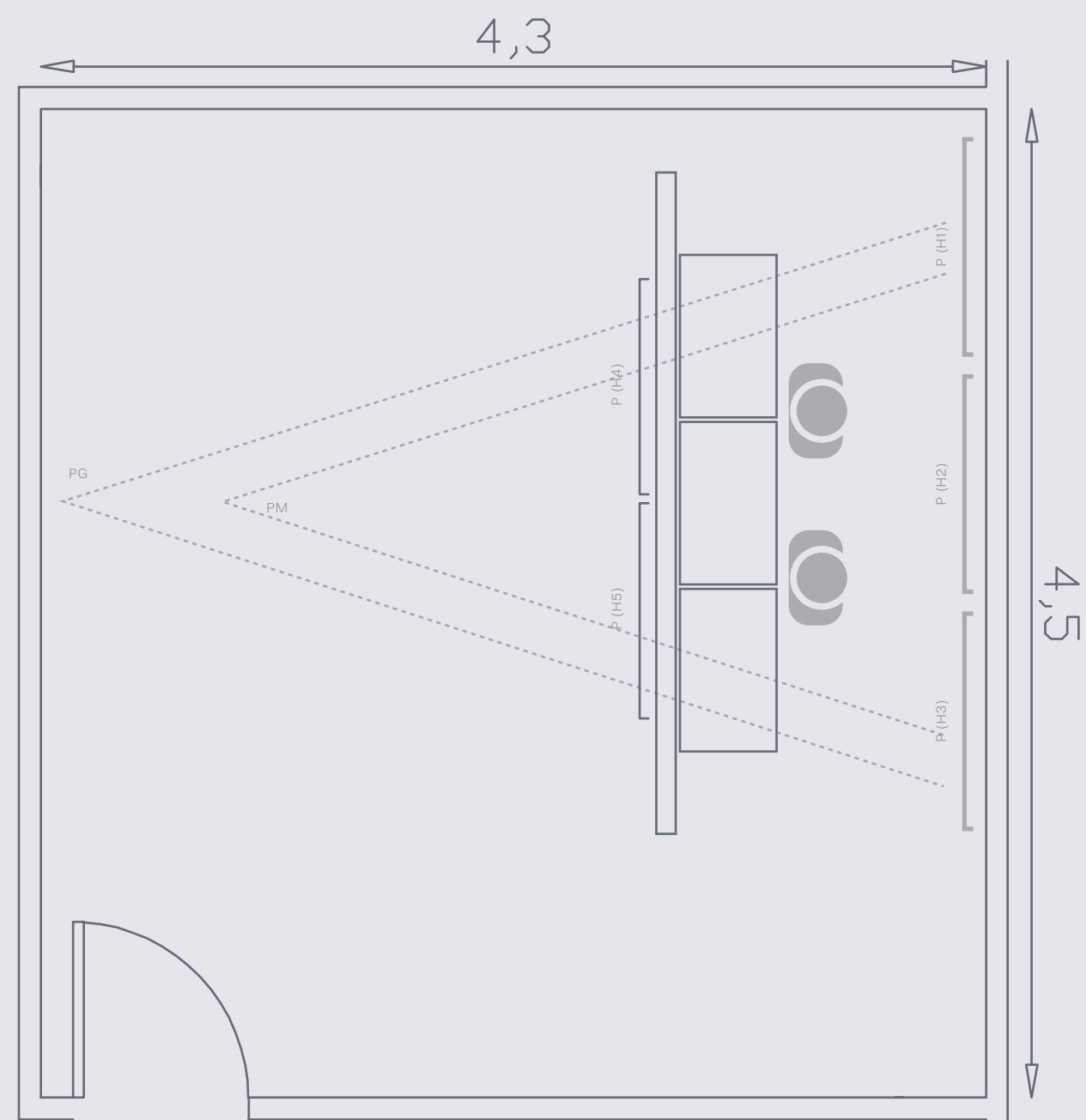



SET #1

EXAMPLE C

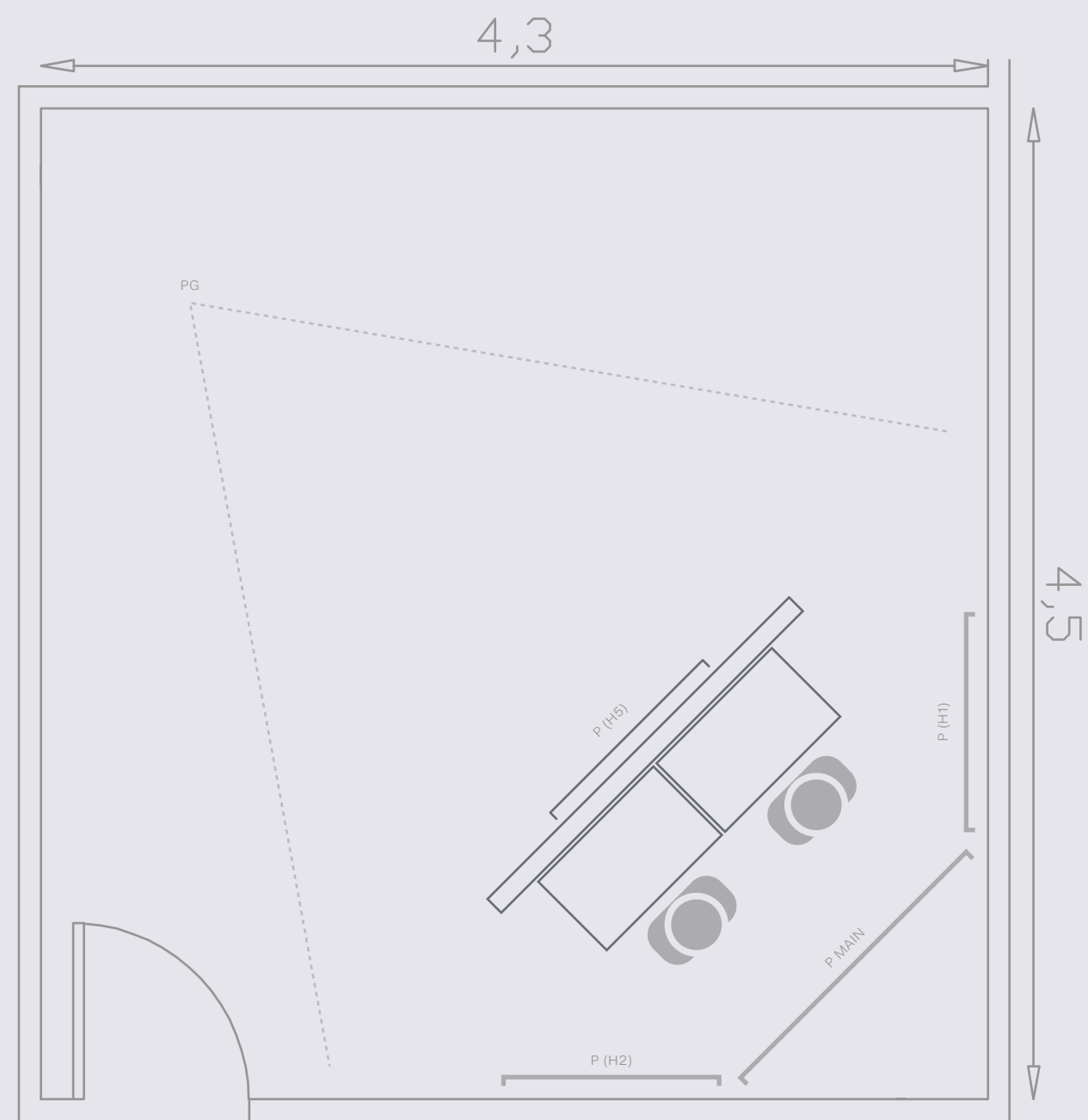



SET #1

EXAMPLE D

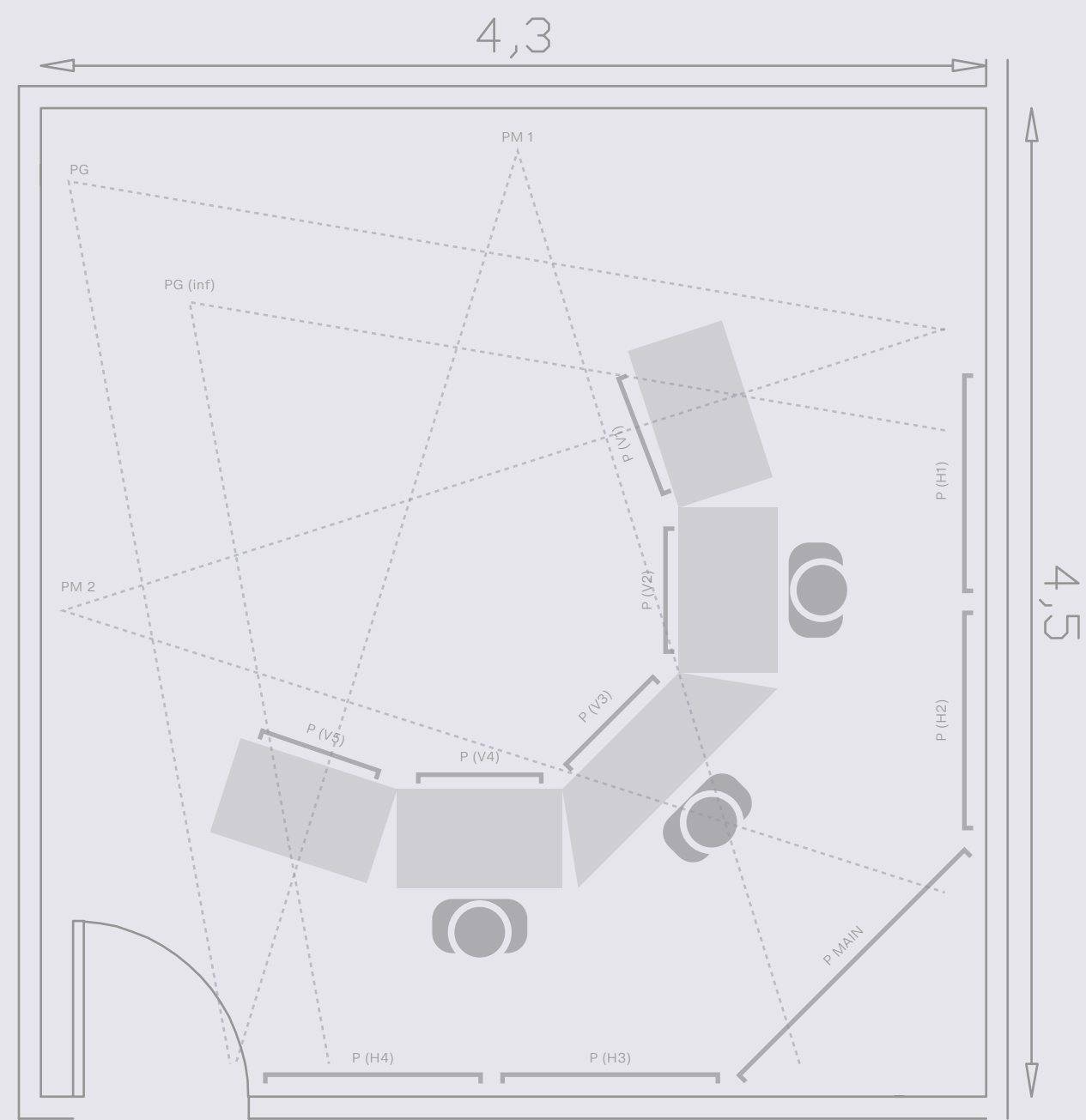



SET #1

EXAMPLE E

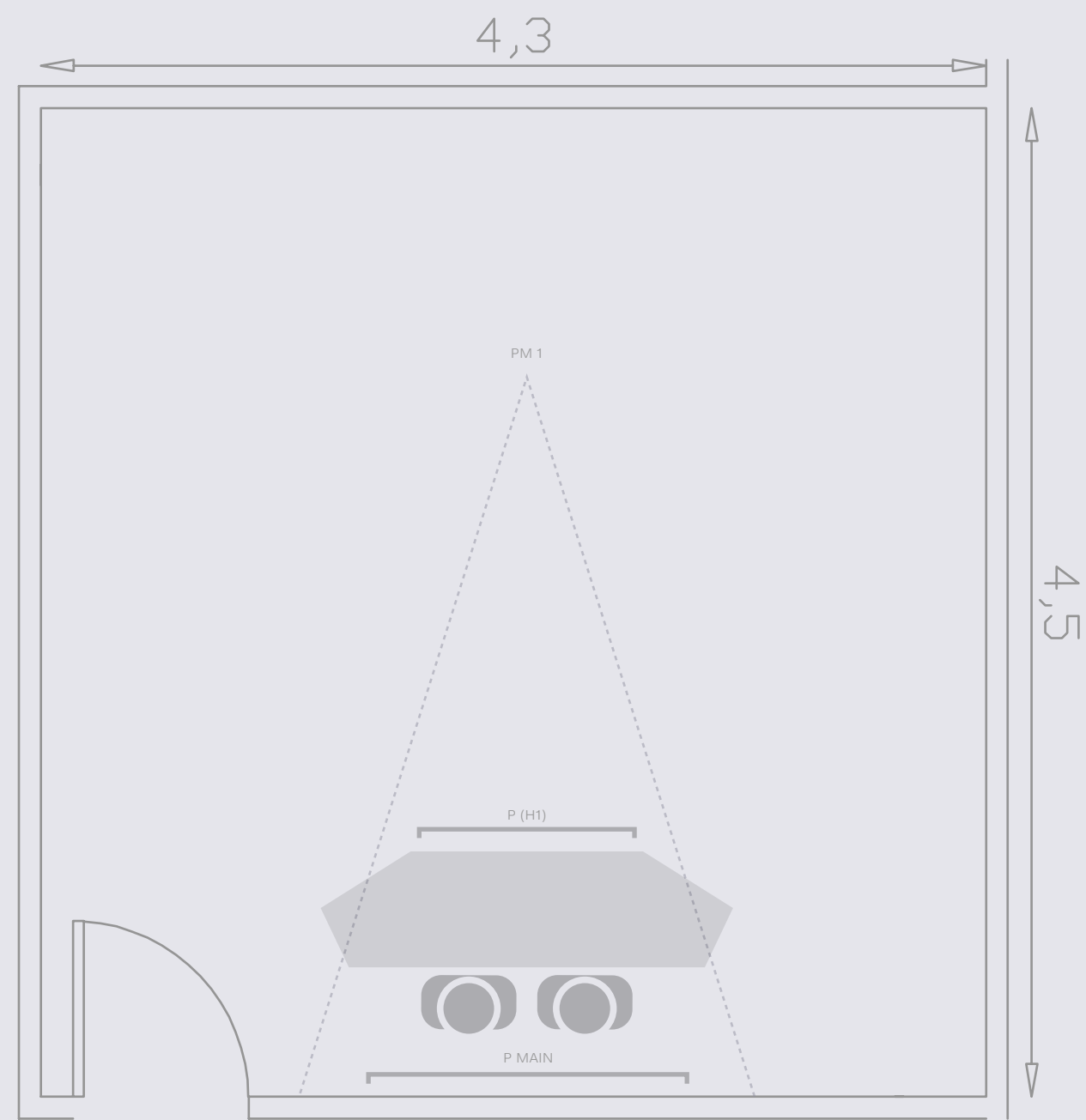

SET #2

CROMA

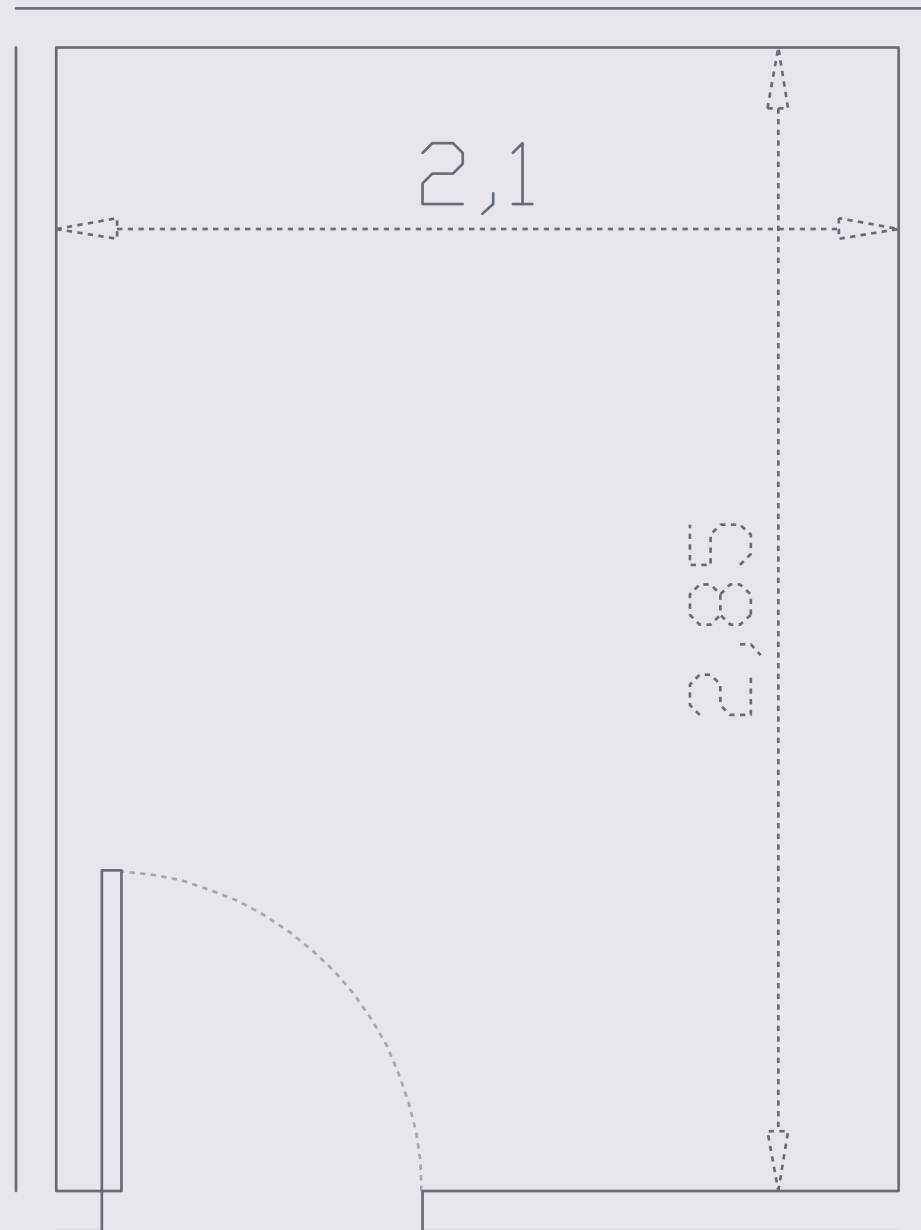



SET #3

CROMA

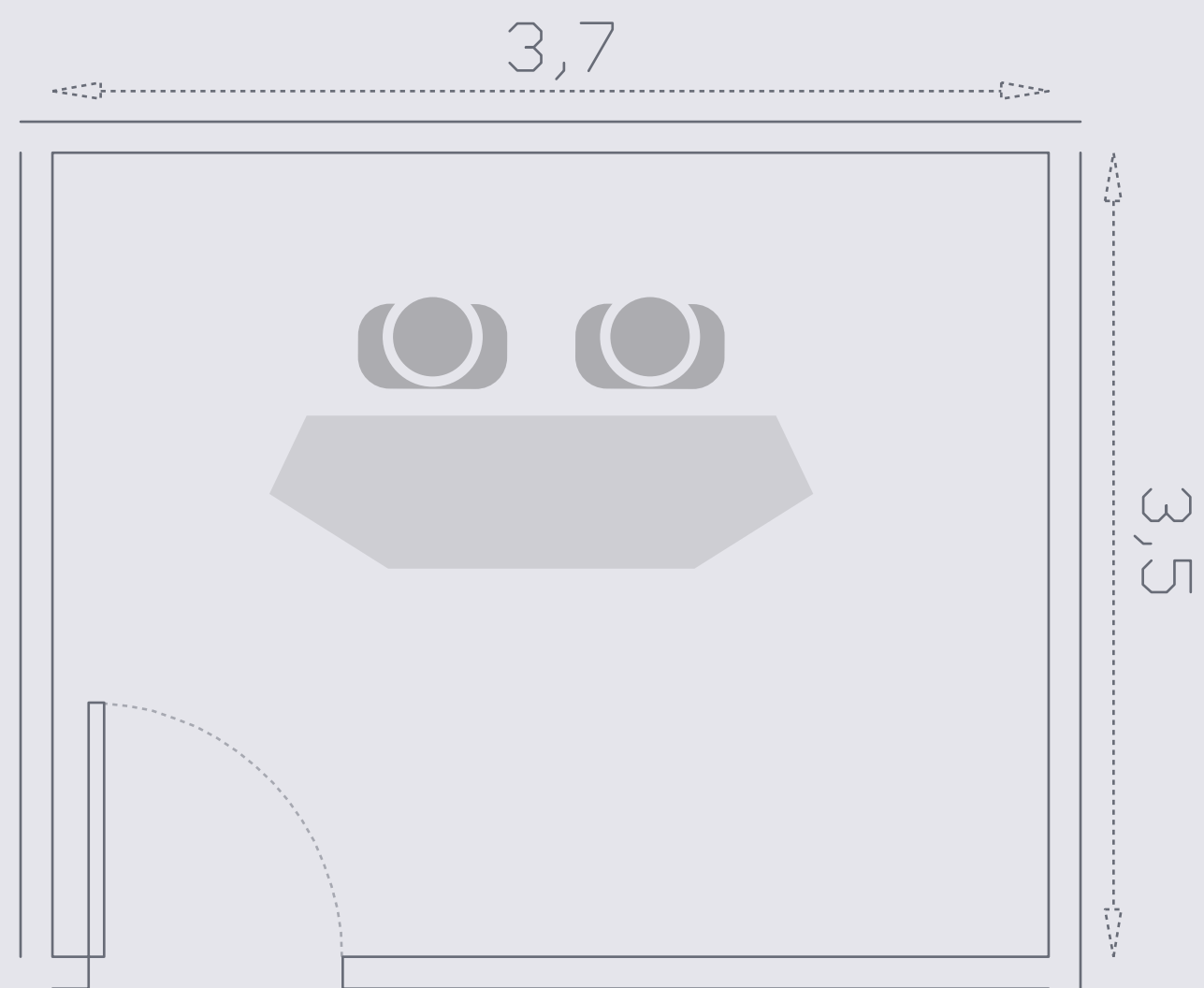

SET #4

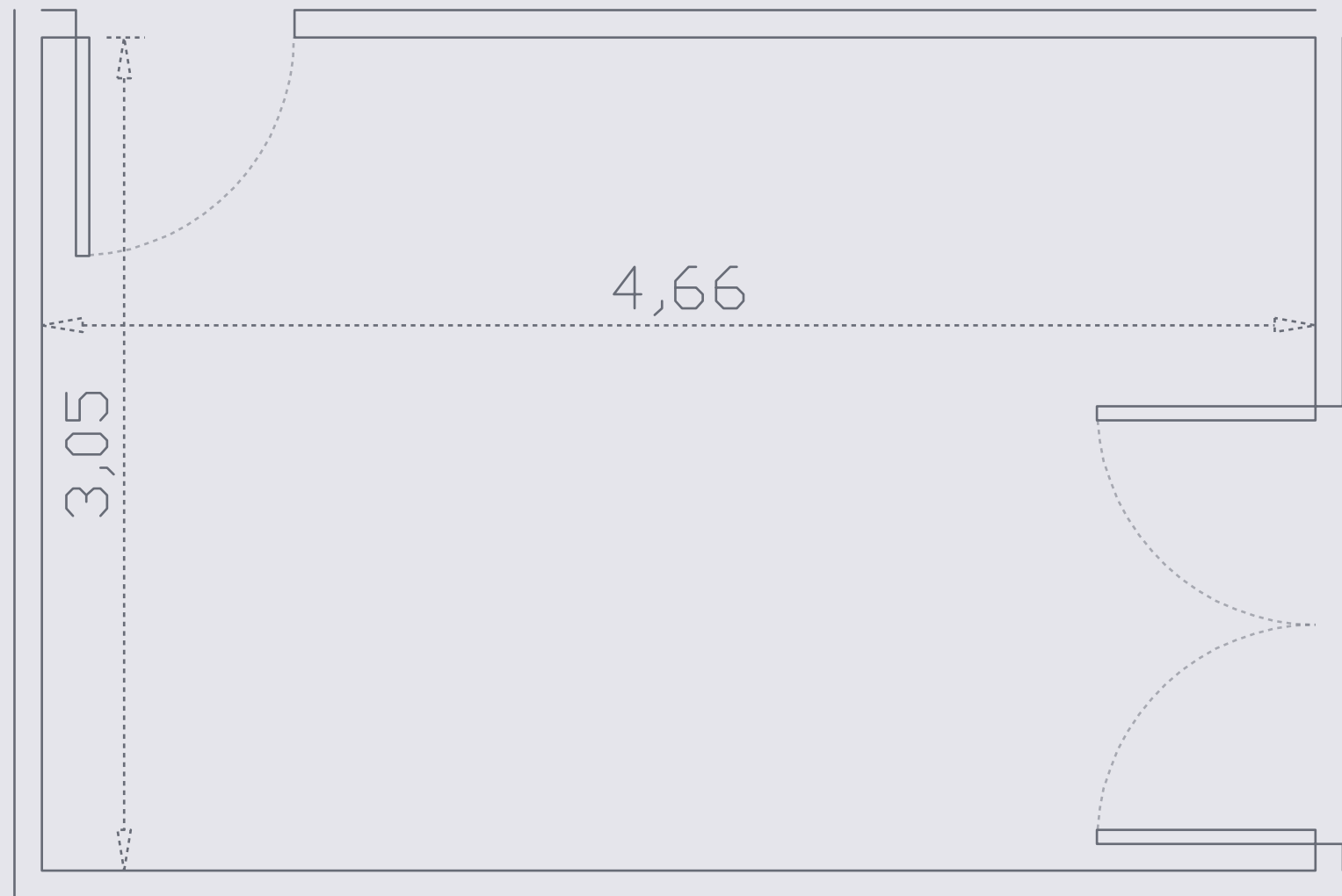



SOME CROMA EXAMPLES

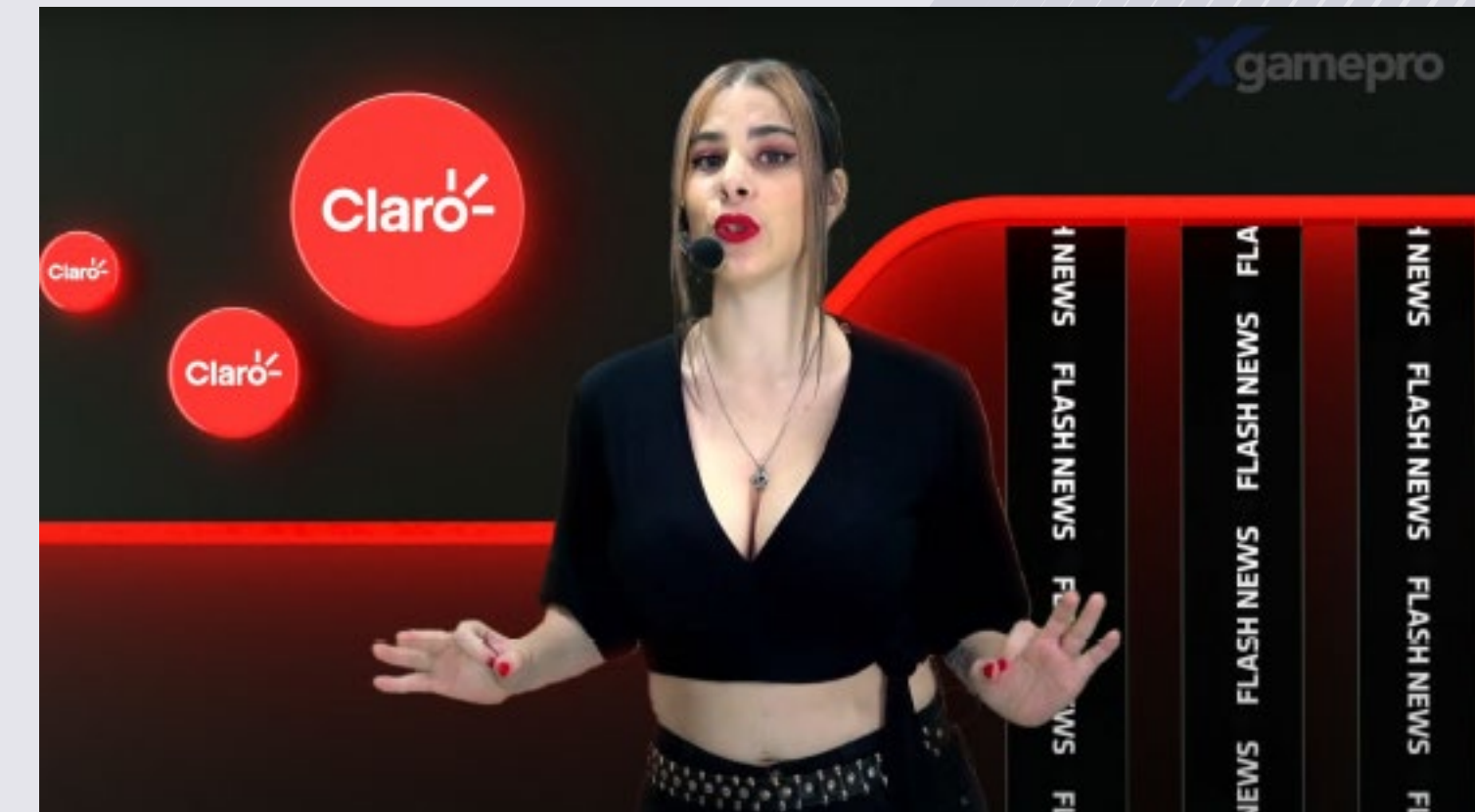



SCENOGRAPHY & WARDROBE

XGamePro guarantees a complete job in this areas in order to create the best possible atmosphere for each broadcast.



WARDROBE

A dedicated wardrobe and makeup help setting up the broadcast's narrative and creating a better context for each character and personality.



Kronopia being made up for Halloween - Garena Free Fire: Halloween



Kronopia ready for the broadcast - Garena Free Fire: Halloween



Magui is ready for the broadcast - Garena Free Fire: Halloween



Kronopia's selfie for social media - Garena Free Fire: Dia de Muertos



SCENOGRAPHY

As wardrobe helps our personalities, a well-done, custom scenography enhances the physical space to better fit the show's image.



Complete view of the 82'' Television - Garena Free Fire: Dia de Muertos



Mexican festive adornments - Garena Free Fire: Dia de Muertos



Areaway adapted for Halloween - Garena Free Fire: Halloween



Areaway adapted for Halloween - Garena Free Fire: Halloween

SUMMARY OF OUR MULTIMEDIA PRODUCTIONS:

YEAR	Content	Game	Client	Link
2020	Christmas	FreeFire	Garena Latam	▶
2020	Día de Muertos	FreeFire	Garena Latam	▶
2021	Halloween	FreeFire	Garena Latam	▶
2021	Casa de Papel	FreeFire	Garena Latam / Netflix	▶
2021	Redragon Latam Series - Matches	CS:GO	Redragon / Flow	▶
2021	Redragon Latam Series - Regional Finals	CS:GO	Redragon / Flow	▶
2021	Redragon Latam Series - Super Finals	CS:GO	Redragon / Flow	▶
2021	Ladder Cup - Matches	LOL	1Block	▶
2021	Ladder Cup - Finals	LOL	1Block	▶
2021	Showmatchs Acer (Goncho & Straka)	CS:GO	Acer/ Intel	▶
2022	Showmatchs Acer (Straka & Baldu)	CS:GO	Acer/ Intel	▶
2022	Axie Infinity	Axie Infinity	Oficial	▶
2022	Ladder League	LOL	1Block	▶
2022	TLF Series Cup	Valorant	Telefe / Paramount	▶



BRANDS THAT HAVE WORKED WITH US:





MORE THAN 10 YEARS IN THE INDUSTRY

The video player displays a broadcast control room. The main monitor shows a 'REIGN VIES' logo with a woman in a red dress. Below it are smaller monitors showing 'GANZ DOB', a color calibration chart, and 'flow'. At the bottom, a timeline is visible with years from 2011 to 2021. A large white play button is centered over the video.



CONTACT US

DARIO CARMONA

📞 11 2022 024 ✉️ dcarmona@xgamepro.net

XGAMEPRO SRL:

Sarmiento 760 - 4to piso, Depto "B".
Ciudad Autónoma de Buenos Aires - Argentina.

XGAMEPRO LLC

1110 Brickell Ave Ste 200, Miami, FL 33313, USA

LOCATION IN ARGENTINA

